



Schwiebacher Abbruch Technik

Werkstatt • Lager • Service seit 1977

D-82229 Seefeld (bei München)

Graf-Toerring-Seefeld-Strasse 9b / 17

Tel. 08152 / 998 969-0 Fax.- 9

T.48/T.50 GRABENRÄUM-SCHWENK-LÖFFEL *optimal** (2 Zylinder stehend, rundes Profil) für Bagger von 7,1 bis 12,5 to

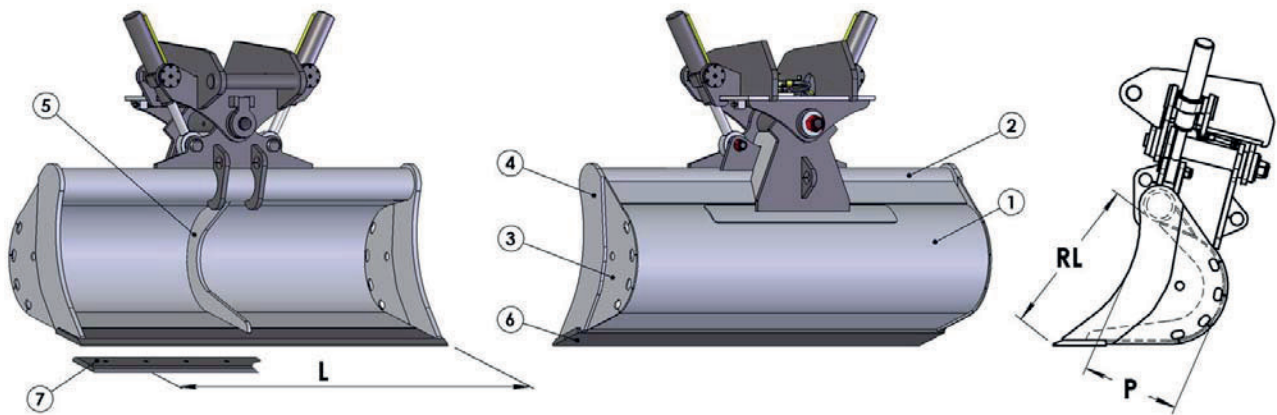
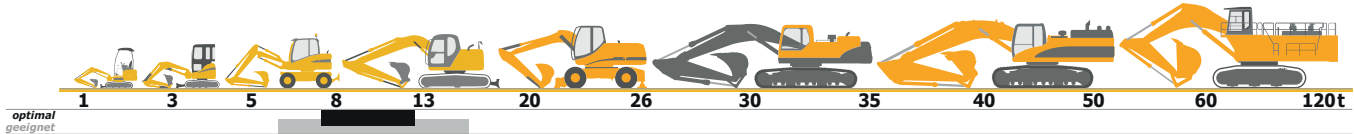

Klasse Class Classe	Bestell Nr. Code Code	L mm.	Cap. SAE Lt.	Anz. Zylinder Cylinders Vérins	Gewicht kg Weight Poids	RL mm.	P mm.	Preis Price List Tarif	Unterschraubmesser Bolt on Blade Lame boulonnées
T.48 T.50 7,1-12,5 ton	T48ORR140	1400	287	2	419	531	337		
	T48ORR150	1500	310	2	431				
	T48ORR160	1600	332	2	443				
	T48ORR180	1800	377	2	466				
	T48ORR200	2000	422	2	490				
		1	2	3	4	5	6	/	7 Optional
Material	Material Matériel	Fe 510	Fe 510	Fe 510	Fe 510	Fe 510	Hb 400	/	Hb 400
Stärke	Thickness Espessure	8 mm	114.3 x 12.5 mm	6 mm	12 mm	15 mm	200 x 20 mm	/	150 x 20 mm

*optimal = für Bagger von 7,1 bis 12,5 t mit Standard-Ausrüstung.

T.48 Atlas 1004/1102D; Benati 3.06/3.07R/3.08R/5.08/5.10; BobCAT 442; Case 488/9007/WX 90/WX 95/CX 75/CX 75SR/CX 80; Caterpillar E 307/E 70/E 70B/307C/308C CR; Daewoo Doosan 070-III/075-V; Eurocomach ES-800; Euromach 8500/TIGRONE; Fai 409/410C/W/750 C/900CH/GTH/GTV; Fiat Hitachi EX 60/EX 60.5/E X 60WD/FH 65W/EX 75U R/EX 75US/FH 85W/FH 9 0WT/FH 95; Fiat Kobelco E 70SR/E 80 SR; Hanix H 75B; Hitachi ZX 70/ZX 80SB/ZX 85US; Hydrema R 800; Hyundai R 95W-3; Ihi-Imer 80 NX/80NX3; JCB JS 70/JZ 70/8080ZTS; Kammo MOBIL 70; Kobelco SK 75UR/SK 80 MSR/YUTANI SK 03; Komatsu PC 75/75R/PC 75R2/PC 75UU/PC 75UU/PC 78MR6/PC 95R/PC 95R2/PW 75/PW 95/PC 58U; Kubota KX 251; Kramer 806/808; Liebherr A 307/A 308/R 308; Macmoter M 7/M 8/M 8M/M 10/BW 75/BW 95; Mecalac 11CX/12CX/12MX/12MSX; Neuson 7002RD/8002RD/75Z3; New Holland E 80MS R; O&K 2.8C/2.8D/MH 2.5; Schaeff HR 41/HML 40/HML 41/HML 42/HS 40A/B/D/HS 41/SKB 1000; Takeuchi TB 80FR/TB 175/TB 175W; Terex 960/970; Venieri VF 12.23; Volvo E CR 88; Yanmar Vio 75/Vio 100.

T.50 Akermann H 3B; Atlas 1104/1204; Benati 3.12R; Benfra 3R/3C; BobCAT 444; Case WX 120; Cosmoter BAT 10; Euromach 9000/9500; Fiat Hitachi FH 115W/FH 120W/EX 100/FH 115; Fiat Kobelco E 115SR/EX 125W; Hitachi ZX 110; Hyundai R110LC7; JCB JS 110; Kobelco SK 100/SK 115SR; Komatsu PC 110R/PC 110R1/PW 110R/PC 120; Laltesi 40/111; Liebherr A 309/A 310/A 311; Macmoter M 12M/BW 110; Mecalac 14M X/14MBX; MF 250; Neuson 1002RD/12002RD; New Holland MH 2.6/MH 3.6/E 115SR; O&K MH 2.10/MH 3.5; PMI 450/810R/913; Terex HR 42.

geeignet = für Bagger von 6,0 bis 16 t je nach Ausrüstung. Andere Klassen/Größen bedingt geeignet. Bei Bedarf bitte anfragen!



Schwiebacher Abbruch Technik

Werkstatt • Lager • Service seit 1977

D-82229 Seefeld (bei München)

Graf-Toerring-Seefeld-Strasse 9b / 17

Tel. 08152 / 998 969-0 Fax.- 9

T.55/T.60 GRABENRÄUM-SCHWENK-LÖFFEL *optimal** (2 Zylinder stehend, rundes Profil und rückwertiger Schneide) für Bagger von 12,5 bis 19 to

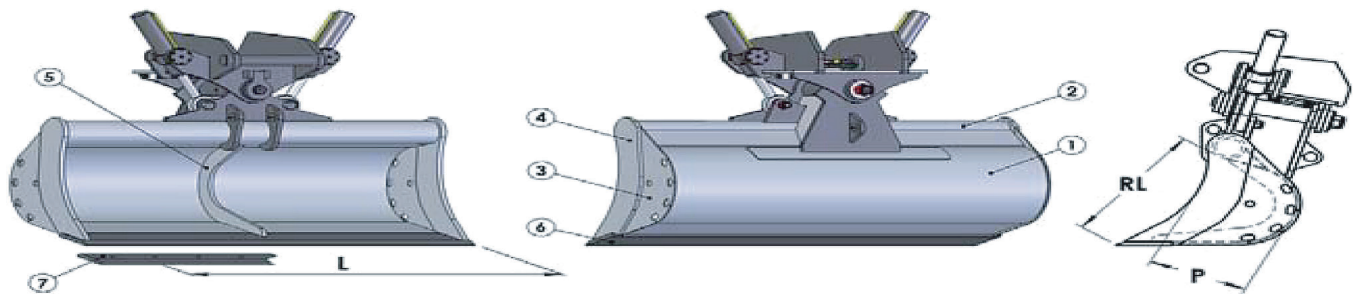
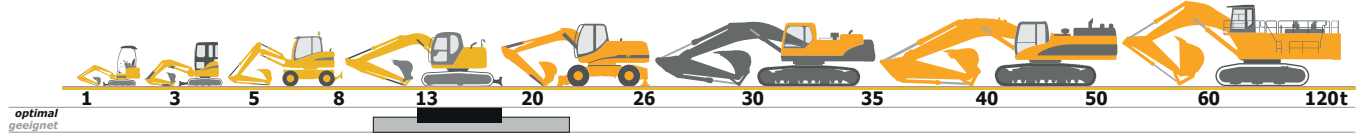

Klasse Class Classe	Bestell Nr. Code Code	L mm.	Cap. SAE Lt.	Anz. Zylinder Cylinders Vérins	Gewicht kg Weight Poids	RL mm.	P mm.	Preis Price List Tarif	Unterschraubmesser Bolt on Blade Lame boulonnées
T.55 T.60 12,5-19 ton		1500	363	2	641	569	427		
		1800	442	2	688				
		2000	495	2	719				
		2200	548	2	759				
		1	2	3	4	5	6	/	7 Optional
Material	Material <i>Matériel</i>	Fe 510	Fe 510	Fe 510	Fe 510	Fe 510	Hb 400	/	Hb 400
Materialstärke	Thickness <i>Espessore</i>	8 mm	127 x 14.2 mm	6 mm	20 mm	15 mm	200 x 25 mm	/	200 x 20 mm

**optimal = für Bagger von 12,5 bis 19 t mit Standard-Ausrüstung.*

T.55 Akermann H 5; Atlas 1302/1304M/1304LC/1404M/14 04LC; Benati 90/120/140/145/3.15/3.16/3.17; Benfra 4R/4C/5/9.05/9.06; Case 588/9013/CX 130/CS 135SR/WX 125/WX 145; Caterpillar EB 120/205/206/M 312/M 313C/M 315/311C/312C/314C; Cosmoter BAT 12/14; Daewoo Doosan DH 130.2/S 110/S 130W-III/S 1 30LCV/S 140WV/S 160W V/S 140LCV/S 150LCV; Fai 1000 C/CH/GTH; Fiat Hitachi FH 120/FH 125W/FH 130.3/EX 135; Fiat Kobelco E 13 5/E 135SR/E 145W; Fiat-Allis E 12/FE 14/FE 16; Ford 42; Furukawa W 625E/W 630/W 635/W 725LS/W 730LS; Halla HE130W/H E 130LC; Hitachi ZX 130/ZX 135US/ZX 130W; Hydromac H 75; Hyundai 120W/R 130W-3/140W-7/R 130LC-3/R 140LC-7; JCB JS 130/JS 130W/JS 140/JS 145W; Kobelco SK 120/SK 135SRLC/90 3B; Komatsu PC 130/PW 130-7/PC 138US-2/PC 150.3; Laitesi 50/221/222; Liebherr R 310B/R 312/A 312 LIT/A 314/A 316/A 900; Mecalac 714MC/714MW; MF 330; New Holland E 145/E 135SRLC/SRL/MH CITY/MH 4.6; O&K RH 4/RH 4PLUS/RH 4PMS/RH CITY/MH 4/MH CITY/MHS/MH PLUS/RH 4.5/RH PLUS; PMI 700/8.15/8.17; Poclair TCS 45/60; ROCK 75; Samsung SE 130LC.2/SE 130W.3; Takeuch TB 1140; Volvo EC 130/EW 130/EC 140B/EW 140B/EC 150/EW 160 B.

T.60 Akermann H 7B/H 7C; Atlas 1604M/1604LC/1622; Benati 160/3.18; Benfra 6C/7R/7.07/7.08/9.07/9.08/9.20; Case 688/688B/788/CX 160/WX 150/WX 165/WX 170/CX 180; Caterpillar 211/212/213B/214/214B/315/317/318/M 316C/M 318C/315C; Cosmoter BAT 16; Daewoo Doosan DH 170/DH 180/S 170III/V/S 175LCV/S 180WV; FAI 1100; Fiat Hitachi FH 150.3/EX 165/FH 150 W.2/FH 150W.3; Fiat Kobelco E 165 LC/E 175W; Fiat-Allis FE 18; Ford 44/45; Furukawa 635E; Hitachi ZX 160LC/ZX 180LC/ZX 160W/ZX180W; Hydromac H 85; Hyundai R 160LC-3/7/R 170W-3/R 180LC-3/7; JCB JS 150/JS 160LC/JS 160W/JS 175W/JS 180LC; Kobelco SK 150/SK 160LC/904/905B/SK 170LC; Komatsu PC 160-7/PW 160-7/PW 170/PC 180-7/PW 1 80-7; Laitesi 80/341/341HD; Liebherr A 9 00C/A 900B LIT/A 902 LIT/A 314 LIT/A 316 LIT/R 317; MF 350D/350E; New Holland E 175/MH PL US/MH PLUS C/MH 5.6; O&K RH 5/RH 5PLUS/RH 5 PMS/MH 5/MH 5PMS/RH 5.5; PMI 900/8.18; Poclair 61/75/688; ROCK 100; Samsung SE 170W.3; Volvo EC 160B/EC 170/EW 170/EC 180B/EW 180B.

geeignet = für Bagger von 10 bis 22 t je nach Ausrüstung. Andere Klassen/Größen bedingt geeignet. Bei Bedarf bitte anfragen!



T.65 GRABENRÄUM-SCHWENK-LÖFFEL *optimal** (2 Zylinder stehend, rundes Profil) für Bagger von 19 bis 23 to

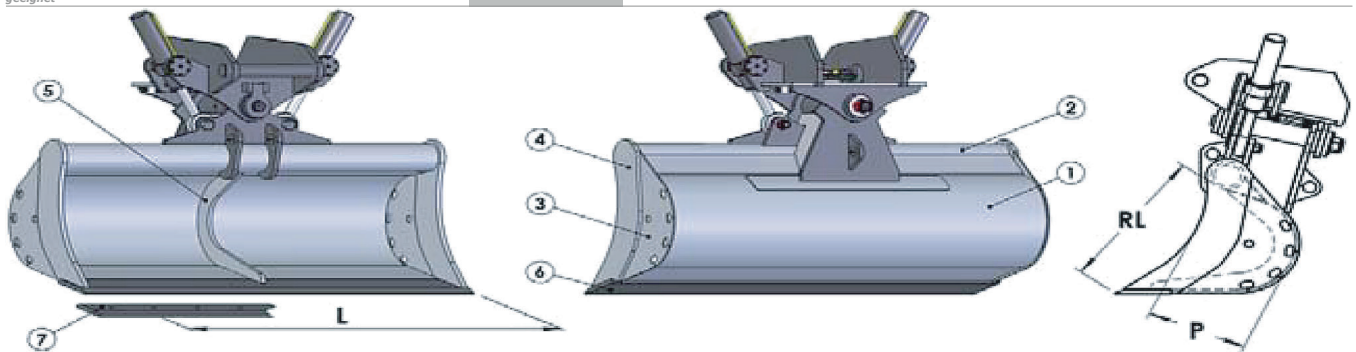
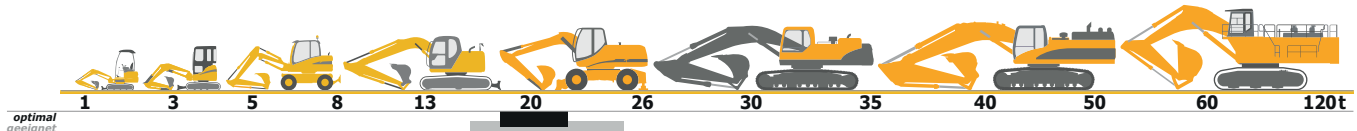

Klasse Class Classe	Bestell Nr. Code Code	L mm.	Cap. SAE Lt.	Anz. Zylinder Cylinders Vérins	Gewicht kg Weight Poids	RL mm.	P mm.	Preis Price List Tarif	Unterschraubmesser Bolt on Blade Lame boulonnées
T.65 19-23 ton	T65ORR180	1800	554	2	712	650	381		
	T65ORR200	2000	620	2	743				
	T65ORR220	2200	687	2	784				
	T65ORR240	2400	750	2	813				
	T65ORR250	2500	783	2	829				
		1	2	3	4	5	6	/	7 Optional
Material	Material <i>Matériel</i>	Fe 510	Fe 510	Fe 510	Fe 510	Fe 510	Hb 400	/	Hb 400
Stärke	Thickness <i>Espessore</i>	8 mm	127 x 14.2 mm	8 mm	25 mm	20 mm	250 x 25 mm	/	200 x 20 mm

*optimal = für Bagger von 19 bis 23 t mit Standard-Ausrüstung.

Atlas 1702D/1704D/1704LC; **Benati** 190CSB/3.20/3.21; **Benfra** 8C/9.09; **Case** 888/888B/988/9021/CX 210/WX 185/WX 200/WX 210; **Caterpillar** 215C/219C/318B/319C/M 320/M 322C; **Cosmoter** BAT 18C; **Daewoo Doosan** S 200WIII/V/S 210WV/DH 220LC/S2 20LCVIII/V/S 225LCV; **FAI** 1200/1300CH/GTH/1400/1500; **Fiat Hitachi** FH 200W.3/EX 200/EX 215; **Fiat Kobelco** E 200SR/E 215 E; **Fiat-Allis** FE 20; **Ford** 47; **Furukawa** 640E/W 735LS/W 738LS; **Hitachi** ZX 210/ZX 210LC/ZX 21 0N/ZX 210W/ZX 225USR/ZX 225USRLC/ZX 225US/ZX 225USLC; **Hydromac** H 95/H 105/H 115; **Hyundai** R 200W/R 200LC/R 210LC-3/7; **JCB** JS 200W/JS 200 LC/JS 210/JS 220; **Kobelco** SK 200/SK 210LC/907/SK 200SR; **Komatsu** PC 200/PC 210/PC 228US-3/P W 200-7/PW 210/PW 220-7; **Laltesi** 441HD; **Liebherr** A 904C/A 904 LIT/A 912 LIT/A 914B/A 914 LIT/R 900B/C LIT/R 904 L IT; **MF** 450D/450E; **New Holland** E 215/E/LC/E 195EL/LC/E 200SR/SRLC/MH 6.6/MH 8.6; **O&K** RH 6B/C/D/E/F/MH 6B/C/D/E/F/RH 6 COMPAC; **PMI** 822/9.21/9.22; **Poclain** 81/888; **ROCK** 130/135; **Samsung** SE 210LC.3/SE 210W.2; **Terex** TC 210 LC/TC 210NLC/TC 225LC/TC 225NLC; **Volvo** EC 200/EW 200/EC 210B.

geeignet = für Bagger von 16 bis 25 t je nach Ausrüstung.
Andere Klassen/Größen bedingt geeignet. Bei Bedarf bitte anfragen!



T.66 GRABENRÄUM-SCHWENK-LÖFFEL *optimal** (2 Zylinder stehend, rundes Profil) für Bagger von 23 bis 26 to

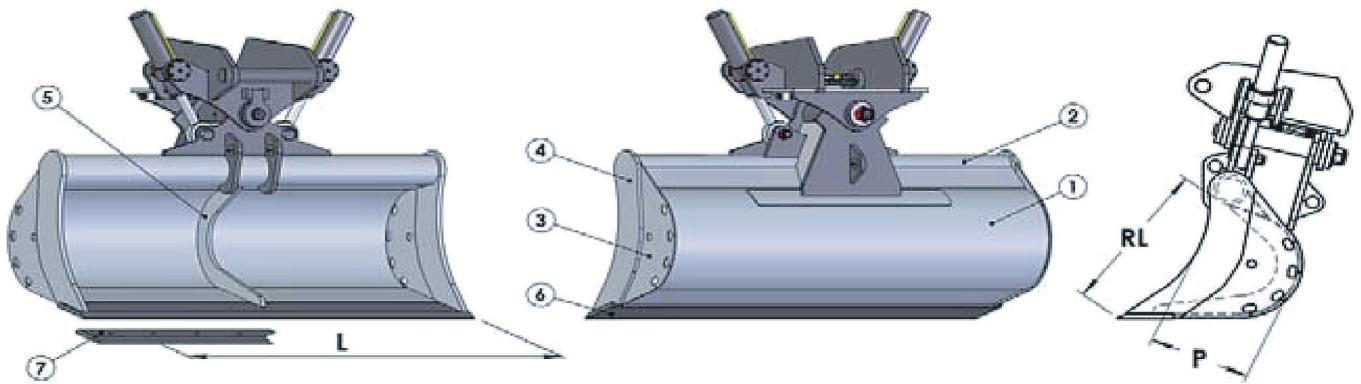
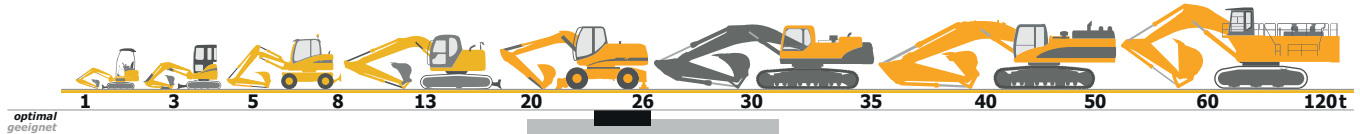

Klasse Class Classe	Bestell Nr. Code Code	L mm.	Cap. SAE Lt.	Anz. Zylinder Cylinders Vérins	Gewicht kg Weight Poids	RL mm.	P mm.	Preis Price List Tarif	Unterschraubmesser Bolt on Blade Lame boulonnées
T.66 23-26 ton	T66ORR180	1800	738	2	796	750	4 60	/	
	T66ORR200	2000	828	2	832				
	T66ORR220	2200	917	2	882				
	T66ORR240	2400	1007	2	918				
	T66ORR250	2500	1052	2	936				
		1	2	3	4	5	6	/	7 Optional
Material	Material Matériel	Fe 510	Fe 510	Fe 510	Fe 510	Fe 510	Hb 400	/	Hb 400
Stärke	Thickness Espessure	8 mm	152.4 x 16 mm	8 mm	25 mm	20 mm	250 x 25 mm	/	200 x 20 mm

*optimal = für Bagger von 23 bis 26 t mit Standard-Ausrüstung.

Akermann H 10B; **Atlas** 1802; **Benati** 3.22/3.22B; **Benfra** 10C/9.10/9.24;
Case 1088/1188/CX 225/CX 255 SR/CX 230/CX 240/WX 240; **Caterpillar** 215D/219D/320B/C/M 325C/321C;
Daewoo Doosan S 240/S 250/S 255LCV; **FAI** 1600; **Fiat Hitachi** FH 220.3/FH 240.3/EX 235/EX 255;
Fiat Kobelco EX 255EL/LC/E 235E/E 235SR; **Fiat-Allis** FE 24; **Ford** 48; **Furukawa** 740LS/640E;
Halla HE 220LC; **Hitachi** ZX 240/ZX 250/ZX 250LC/ZX 250LCN; **Hydromac** H 135/H 145;
Hyundai 228LC/R 250LC-3/7; **JCB** JS 235/JS 240/JS 260; **Kobelco** SK 220/SK 235S R/SK 250LC;
Komatsu PC 220/PC 230N-7/PC 240-7; **Laltesí** 420/500HD; **Liebherr** A 924B/A 924 LIT/R 912 LIT/R 9 14 LIT/R 914B LIT;
New Holland E 245/E 265EL/LC/E 235SRNLC/SRLC; **O&K** RH 6PMS/RH 6.20/RH 6.22/RH 8PMS/MH 8.6/RH 6.5;
PMI 1000/1200/8.25/9.25; **Poclair** 90/115; **Samsung** SE 240LC.3;
Terex TC 240 LC/TC 240NLC/TC 260LC/TC 260NLC; **Volvo** EC 230/EW 230/EC 240B.

geeignet = für Bagger von 18 bis 30 t je nach Ausrüstung.
 Andere Klassen/Größen bedingt geeignet. Bei Bedarf bitte anfragen!



Schwiebacher Abbruch Technik

Werkstatt • Lager • Service seit 1977

D-82229 Seefeld (bei München)

Graf-Toerring-Seefeld-Strasse 9b / 17

Tel. 08152 / 998 969-0 Fax.- 9

T.68/T.69/T.70 GRABENRÄUM-SCHWENK-LÖFFEL *optimal** (2 Zylinder stehend, rundes Profil) für Bagger von 26 bis 43 to

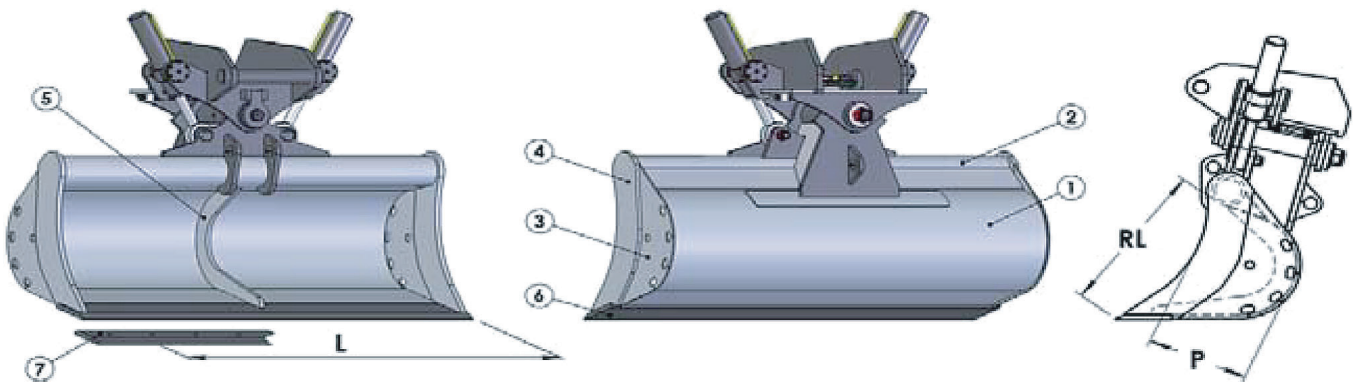
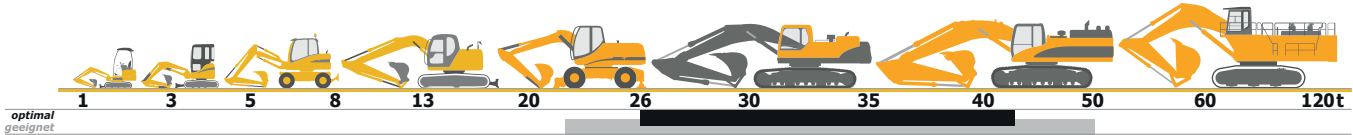

Klasse Class Classe	Bestell Nr. Code Code	L mm.	Cap. SAE Lt.	Anz. Zylinder Cylinders Vérins	Gewicht kg Weight Poids	RL mm.	P mm.	Preis Price List Tarif	Unterschraubmesser Bolt on Blade Lame boulonnées
T.68 T.69 T.70 26-43 ton	T68ORR180	1800	956	2	1210	860	529	/	
	T68ORR200	2000	1074	2	1263				
	T68ORR220	2200	1191	2	1337				
	T68ORR240	2400	1309	2	1390				
	T68ORR250	2500	1366	2	1416				
		1	2	3	4	5	6	/	7 Optional
Material	Material Matériel	Fe 510	Fe 510	Fe 510	Fe 510	Fe 510	Hb 400	/	Hb 400
Stärke	Thickness Espessure	10 mm	177.8 x 20 mm	10 mm	30 mm	25 mm	300 x 30 mm	/	250 x 25 mm

*optimal = für Bagger von 26 bis 43 t mit Standard-Ausrüstung.

T.68 Akermann H 14B; Atlas 1804/1804M/180 4LC/1902; Benati 230CSB/270CSB/370/3.28/3.30; Benfra 12C/9.11/9.12; Case 1288CK/CX 290; Caterpillar 225D/229D/231/322B/322C/323/325B/C/D; Cosmoter BAT 25C; Daewoo Doosan DH 280/280 LCIII/V/290LCV/S 300LCV; Fiat Hitachi FH 270.3/ EX 285; Fiat Kobelco EX 285LC; Fiat-Allis FE 28; Ford 50; Furukawa 645LS; Hitachi ZX 28 0LC/ZX 280LCN; Hydromac H 150/H 180; Hyundai 280LC/290 LC-3/7; JCB JS 3 00/JS 330; Kobelco SK 300/909; Komatsu PC 270/PC 280/PC 290-7/PC 300; Laltesi 541; Liebherr A 932 LIT/A 934 LIT/R 924B LIT/R 924 LIT; MF 550; New Holland E 305EL/LC; O&K RH 9E/F/G/PMS/RH 9.5/RH 8.5; PMI 1300/1500/8.30/8.34/9.26/9.30/9.35; Poclair 125; ROCK 150; Samsung SE 280 LC.2; Volvo EC 280/EC 290B.

T.70 Akermann H 16C; Atlas 2004; Benati 335/450/310CSB; Benfra 9.32; Case 1488, 9033/CX 330/CX 350; Caterpillar 330B/C/D/E; Daewoo Doosan DH 320/S 330III/V/S 360LCIII/S 340LCV; Fiat Hitachi FH 300.2/FH 330.3/EX 355; Fiat Kobelco EX 355EL/LC/BEN; Furukawa 650E; Halla HE 360LCH; Hitachi ZX 350LC/ZX 350LCN; Hydromac H 200; Hyundai H 230/H 270/R 320LC-3/7/R 360LC-3/7; Kobelco SK 330LC/912; Komatsu PC 340-7/PC 360; Laltesi 350 HD/551HD; Liebherr A 944 HD LIT/R 934B LIT/R 942 LIT/R 944 LIT/R 944B LIT; New Holland E 335LC/NLC/E 3 85EL/LC/BEH; O&K RH 12.5/RH 14; PMI 14855; Poclair 170; ROCK 200; Samsung SE 350LC.2; Volvo EC 330B/EC 340/EC 360B.

geeignet = für Bagger von 22 bis 45 t je nach Ausrüstung. Andere Klassen/Größen bedingt geeignet. Bei Bedarf bitte anfragen!